

ASKO
BUILT TO LAST LONGER

Spare Parts Catalogue

ASKO Washing Machines \ ASKO 05 Generation
Type: WM100A
Model: 12505 US white

Prod. No: 10712505
January 16th 2013

ASKO Appliances Inc.

4001 E Plano Parkway #1004001 E Plano Parkway #100
Plano, Texas 75074

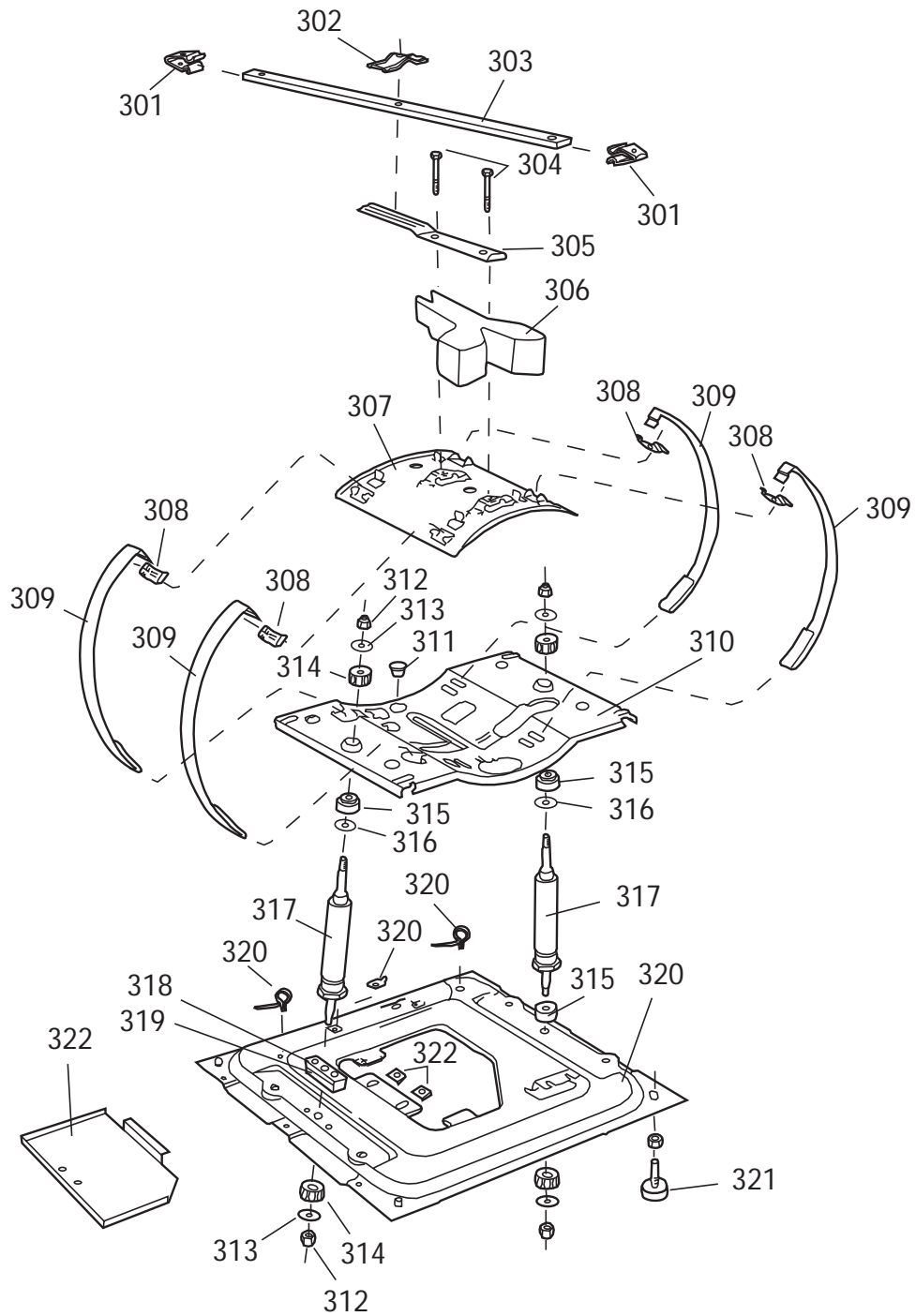
STÖDVAGGA**SUPPORT CRADLE AND RELATED PARTS**

Support Cradle

ASKO, 12505 US - white (WM100A)

Pos	Spare part No.	Description	Qty	Comment
301	8056667	Bracket - Balance Strip	2 Pc's	
301-a	8900327	Screw 20 Torx Self Tapping	2 Pc's	
302	8056668	Holder - Balance Strip	1 Pc's	
302-a	8900327	Screw 20 Torx Self Tapping	1 Pc's	
303	8056654	Balance - 10504	1 Pc's	
304	8901034	Screw	2 Pc's	
305	8007766	Spring Mount - Holder	1 Pc's	
306	8056640-1	Counter Weight 200	1 Pc's	
307	8008288	Lower Weight Bracket	1 Pc's	
308	33256329	Tub Band clip	4 Pc's	
309	33256963	Tub Bands	4 Pc's	
310	8062038	Supp Cradle Comp.	1 Pc's	
311	8055084	Plug	1 Pc's	
312	8901193	Locking Nut	4 Pc's	
313	33256445	washer	4 Pc's	
314	8051155	Rubber Buffer	3 Pc's	
315	8051156	Rubber Buffer	3 Pc's	
316	33250290	Washer	2 Pc's	
317	8801036	Spring Leg	1 Pc's	
318	8056645	U-Plate - 10504	1 Pc's	
319	8056644	Rubber Buffer disc.jh 11-99	1 Pc's	
320	8058036	NLA - Bottom/Base WM80-WM220	1 Pc's	
320-a	33700183	Terminal	1 Pc's	
320-b	8054485	Cable Strip	2 Pc's	
320-c	8900369	Screw T25	13 Pc's	
320-d	8901097	Screw Terminal	1 Pc's	
320-e	8901413	Lock Washer laundry tops	1 Pc's	
321	8059334	Leveling Leg Comp. WMD 20	4 Pc's	

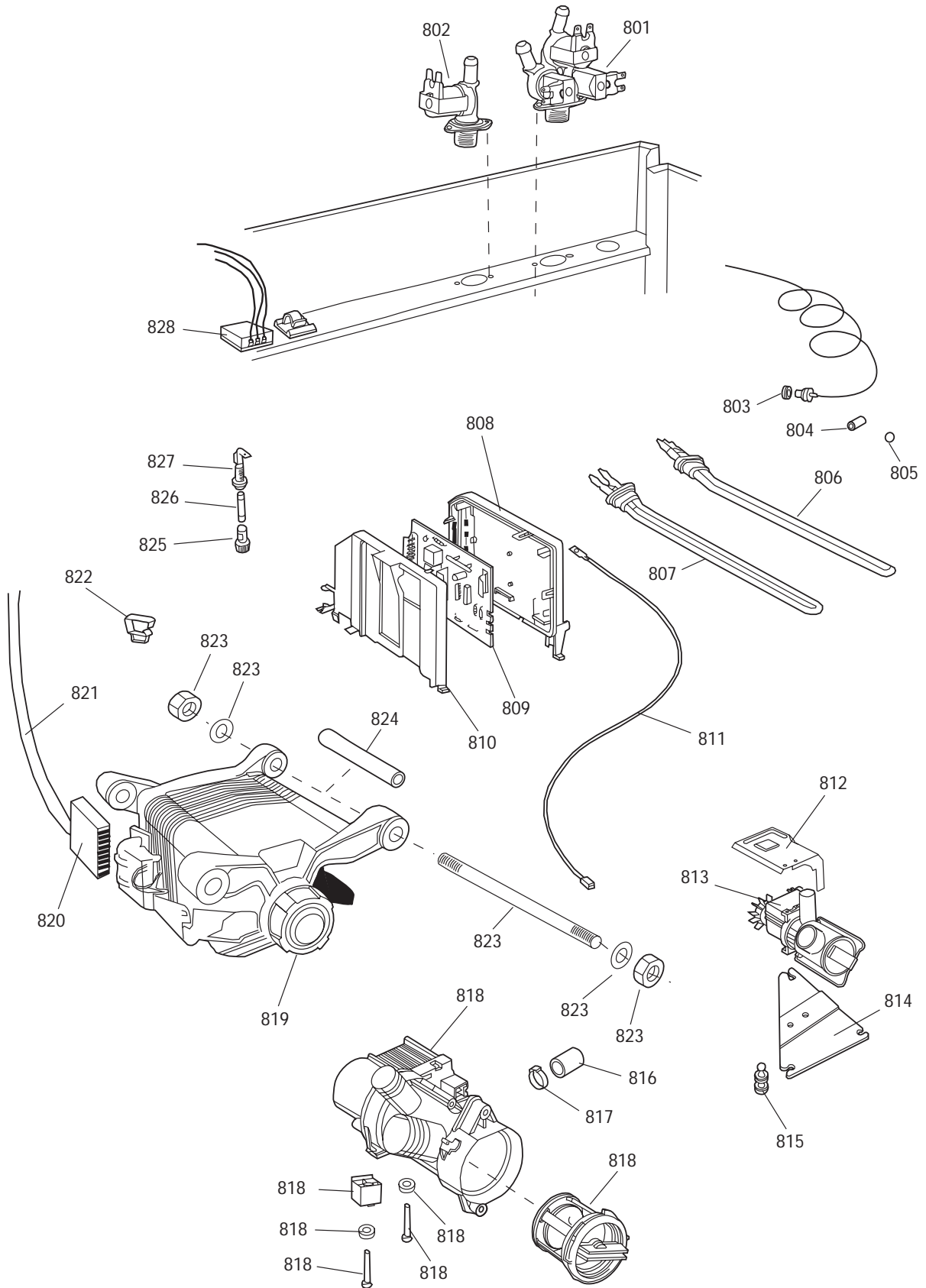

Electric Parts Lower Section

ASKO, 12505 US - white (WM100A)

Pos	Spare part No.	Description	Qty	Comment
801	8008003	Fill Valve 03/05 W/O Clamps WM	1 Pc's	
801-a	8901097	Screw Terminal	2 Pc's	
801-b	8901413	Lock Washer laundry tops	2 Pc's	
803	33651658	T'Stat Seal	1 Pc's	
804	8002259	Plastic Hose	2 Pc's	
805	33700450	Cable Strip	5 Pc's	
806	8058402	Heater WM 1800W 04/05 WM	1 Pc's	
807	8058403	Heater Washer 1200W WM	1 Pc's	
808	8060429	PCB Holder Lower	1 Pc's	
809	8057555	Board Mtr. Cntrl. 12505	1 Pc's	
810	8060430	PCB Holder Upper	1 Pc's	
810-a	8901097	Screw Terminal	1 Pc's	
810-b	8901322	Washer	1 Pc's	
818	8801169	Drain Pump Kit (no housing or insert)	1 Pc's	Does not include Housing or Insert Kit 8801069
819	8063733	MOTOR	1 Pc's	
819-a	8801097	Brush to Motor Chk Model WM	1 Pc's	
822	8058680	Holder Cable	3 Pc's	
823	8063591	Screw	2 Pc's	
823-a	8901155	Nut	2 Pc's	
823-b	8901193	Locking Nut	2 Pc's	
823-c	8901337	Washer	2 Pc's	
824	8058261	Spacer Tube Motor 05 WM	2 Pc's	
825	8801354	Fuse Holder Assembly	2 Pc's	For units produced before wk 34 2002
827	8801354	Fuse Holder Assembly	2 Pc's	For units produced before wk 34 2002

Datum
2003-05-02
Date

PANEL

CONTROL PANEL AND RELATED PARTS

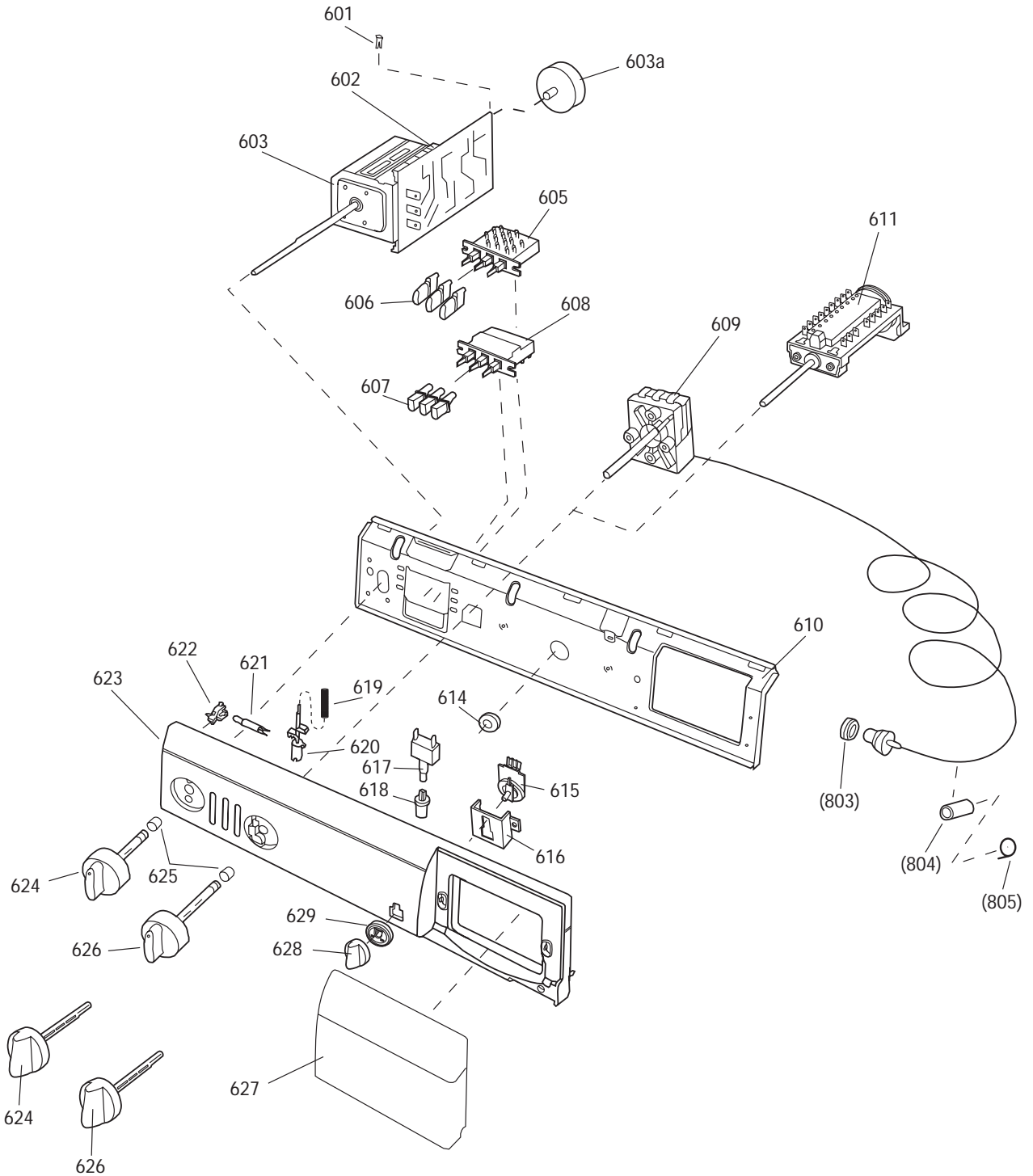

Control/Facial Panel

ASKO, 12505 US - white (WM100A)

Pos	Spare part No.	Description	Qty	Comment
601	8902285	Terminal Crimp	1 Pc's	
602	8902302	Crimp Terminal	1 Pc's	
603	8059481	Timer 12505	1 Pc's	
603-a	8052541	Timer Motor	1 Pc's	
603-b	8900026	Screw Nickel flathead	4 Pc's	
605	8056445	Switch Push Button 12505 Up	1 Pc's	
605-a	8901242	Nut	2 Pc's	
606	8059703-0	Push Button gen. 05 Upper Part	3 Pc's	
607	8059704-0	Push Button gen. 05 Lower Part	3 Pc's	
608	8056446	Switch Push Button 12505 Lo	1 Pc's	
608-a	8901242	Nut	2 Pc's	
609	8801068	T-Stat WM90/110/100/120	1 Pc's	
610	8062035	Front Beam WM 05	1 Pc's	
610-a	8900027	Screw	4 Pc's	
610-b	8902362	Screw 20 Torx Self Tapping	5 Pc's	
610-c	8901413	Lock Washer laundry tops	2 Pc's	
614	8060929	Grommet	1 Pc's	
617	8057941	Switch temp hi/lo DW	1 Pc's	
618	8059705-0	Push Button Main Switch WM/TD	1 Pc's	
619	8060401	Spring Safety Catch	1 Pc's	
620	8059687-0	Safety Catch 05/06 DW	1 Pc's	
621	8060478	Ind. Lamp 600's WM	1 Pc's	
622	8060415	Lens Ind. WM80/90/100/120/70	1 Pc's	
623	8060745-0-UL	Control Panel 12505	1 Pc's	
624	8060680-0	Knob Timer 05 White WM	1 Pc's	
626	8062266-0	Knob temp 10505 12505 13605	1 Pc's	
627	8059677-0-UL	Handle Det Comp WH 05 WM	1 Pc's	

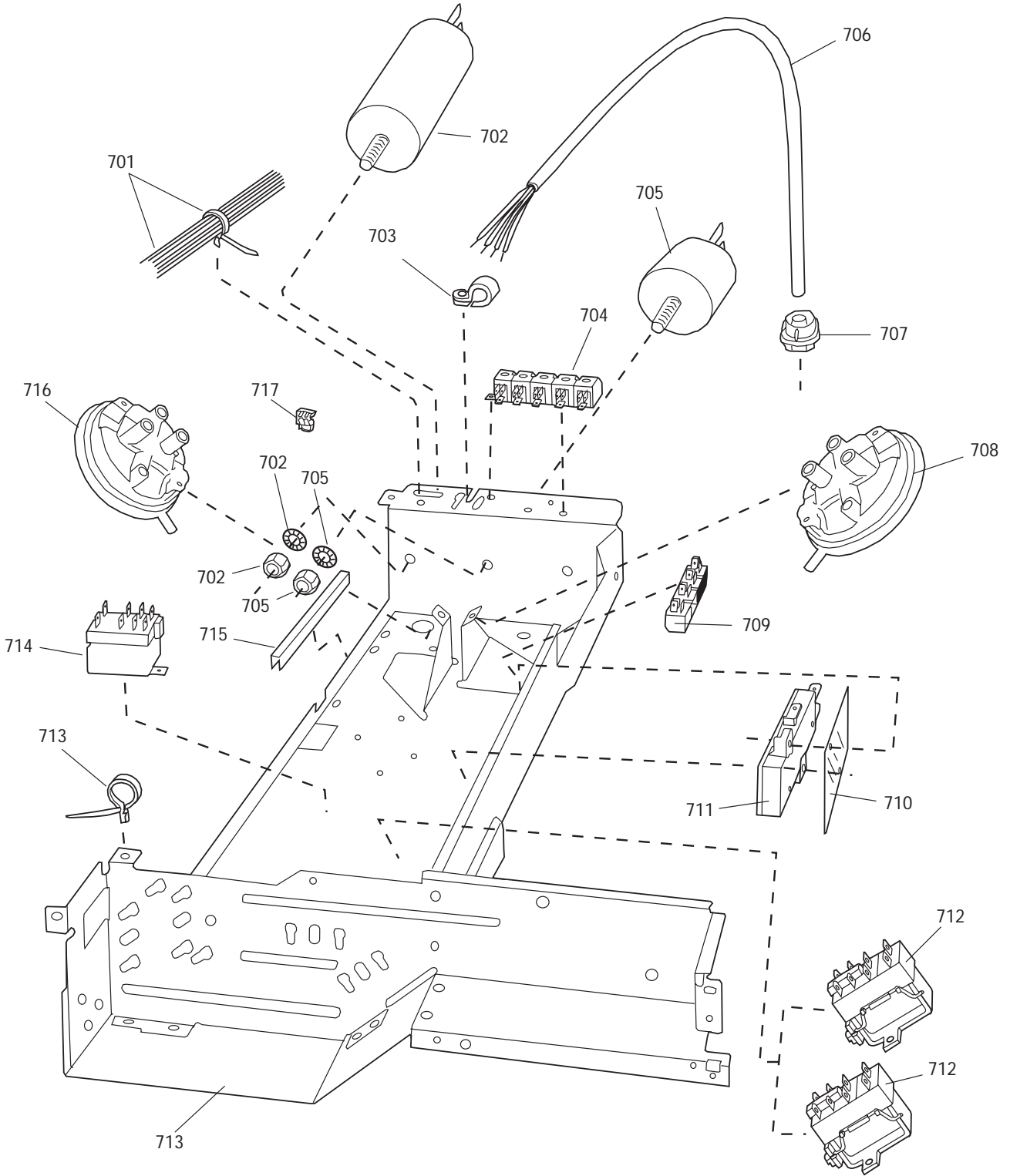

Electric Parts Upper Section

ASKO, 12505 US - white (WM100A)

Pos	Spare part No.	Description	Qty	Comment
701	8060618-UL	Cable Single Phase	1 Pc's	
701	8060619-UL	Cable Rinse Level	1 Pc's	
701	8060623-UL	Cable Cold Fill	1 Pc's	
701	8060975-UL	Cable Fuse Holder	1 Pc's	
702	8058558	RFI 05/06 WM	1 Pc's	
703	8001435	Cable Bracket	1 Pc's	
704	8050250	TERMINAL BLOCK Inside WM/TD	1 Pc's	
704-a	8901413	Lock Washer laundry tops	1 Pc's	
704-b	8902131	Screw	1 Pc's	
706	8060956	Cord Set UL 250V/20A	1 Pc's	
707	8006948	Grommet	1 Pc's	
708	8061593	Level Switch WM.	1 Pc's	
708-a	8902042	Screw Protective Cover Dryer	1 Pc's	
710	8061495	Insul.	1 Pc's	
711	8054295	Lock Relay Door WM 200	1 Pc's	
711-a	8900311	Screw	2 Pc's	
713	8061492	Bracket Comp.	1 Pc's	
713-a	8054485	Cable Strip	1 Pc's	
713-b	8902362	Screw 20 Torx Self Tapping	2 Pc's	
713-c	8901413	Lock Washer laundry tops	1 Pc's	
715	8058703	PROTECTION	1 Pc's	

Datum

2003-05-02

Date

TVÄTTSYSTEM

WASHING SYSTEM

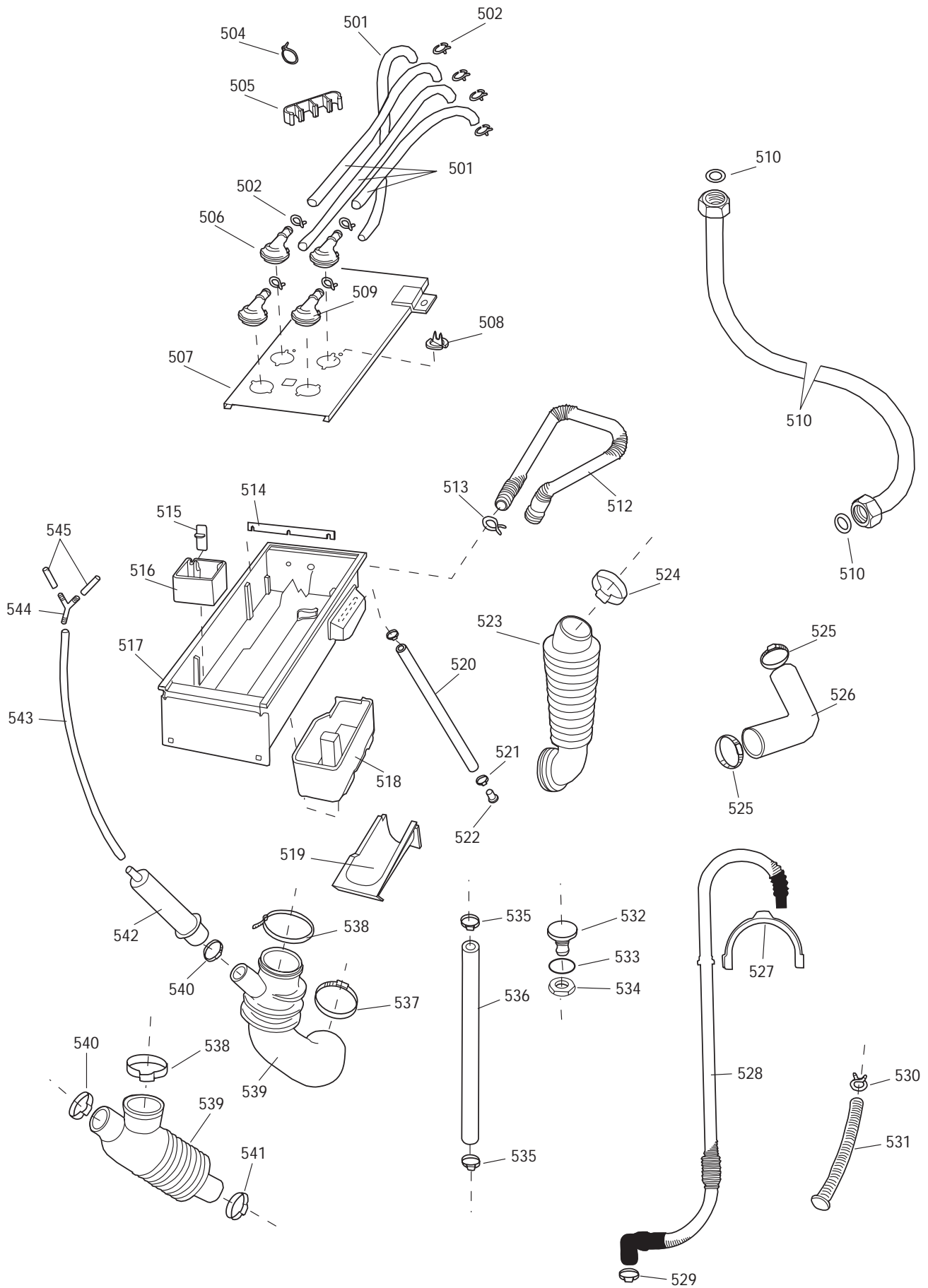

Washing System

ASKO, 12505 US - white (WM100A)

Pos	Spare part No.	Description	Qty	Comment
501	8050535	Rubber Hose	3 Pc's	
502	8056656	Cable Tie	6 Pc's	
504	8002263	Cable Strip	1 Pc's	
505	8051397	Hose Bracket	1 Pc's	
506	8008027	Spray Head WM 03/05	2 Pc's	
507	8056484	Holder - Det Comp	1 Pc's	
507-a	8900026	Screw Nickel flathead	1 Pc's	
507-b	8901242	Nut	1 Pc's	
508	8051646	Hose Holder	1 Pc's	
509	8056638	Spray Head - Washer	1 Pc's	
510	8056950	Fill Hose Pex WM	1 Pc's	
510-a	33700738	Seal	2 Pc's	
512	8056112	Vent Hose WM	1 Pc's	
513	8052730	Hose Clip	1 Pc's	
514	33251781	Subs to 8050633	1 Pc's	
515	8009512	Siphon Tube	1 Pc's	
516	8050551	Disp. Fab. Softener 03/05 WM	Pc's	
516	8050551	Disp. Fab. Softener 03/05 WM	Pc's	
517	8056499-UL	Det. Comp Washer 05	1 Pc's	
518	8051665	detergent Cup Washer	1 Pc's	
520	8056623	Hose Spillway Overflow	1 Pc's	
521	8054196	Clamp	2 Pc's	
522	8053187	Stub Bottom	1 Pc's	
523	8055114	Bellows Hose	1 Pc's	
524	8052069	Hose Clip	1 Pc's	
527	8050805	HOLDER Drain Hose	1 Pc's	
528	8056520	Outlet Hose - 10504	1 Pc's	
529	8056491	Hose Clamp Squeeze	1 Pc's	
530	8052731	Squeeze Clamp	1 Pc's	
531	8060666	Drain Hose Outlet Pump	1 Pc's	
532	8055667	Stub Washer	1 Pc's	
533	7382087	O Ring	1 Pc's	
534	8055668	Nut	1 Pc's	
535	8054196	Clamp	2 Pc's	
536	8056598	Hose - Recirc	1 Pc's	
538	8051392	Hose Clip	1 Pc's	
539	8056380	Bellows Hose Lower 04/05 WM	1 Pc's	
540	8051673	Hose Clip	1 Pc's	
541	8056471	Hose Clips	1 Pc's	
542	8007642	Pressure Chamber	1 Pc's	
543	7382670	Rubber Hose	1 Pc's	

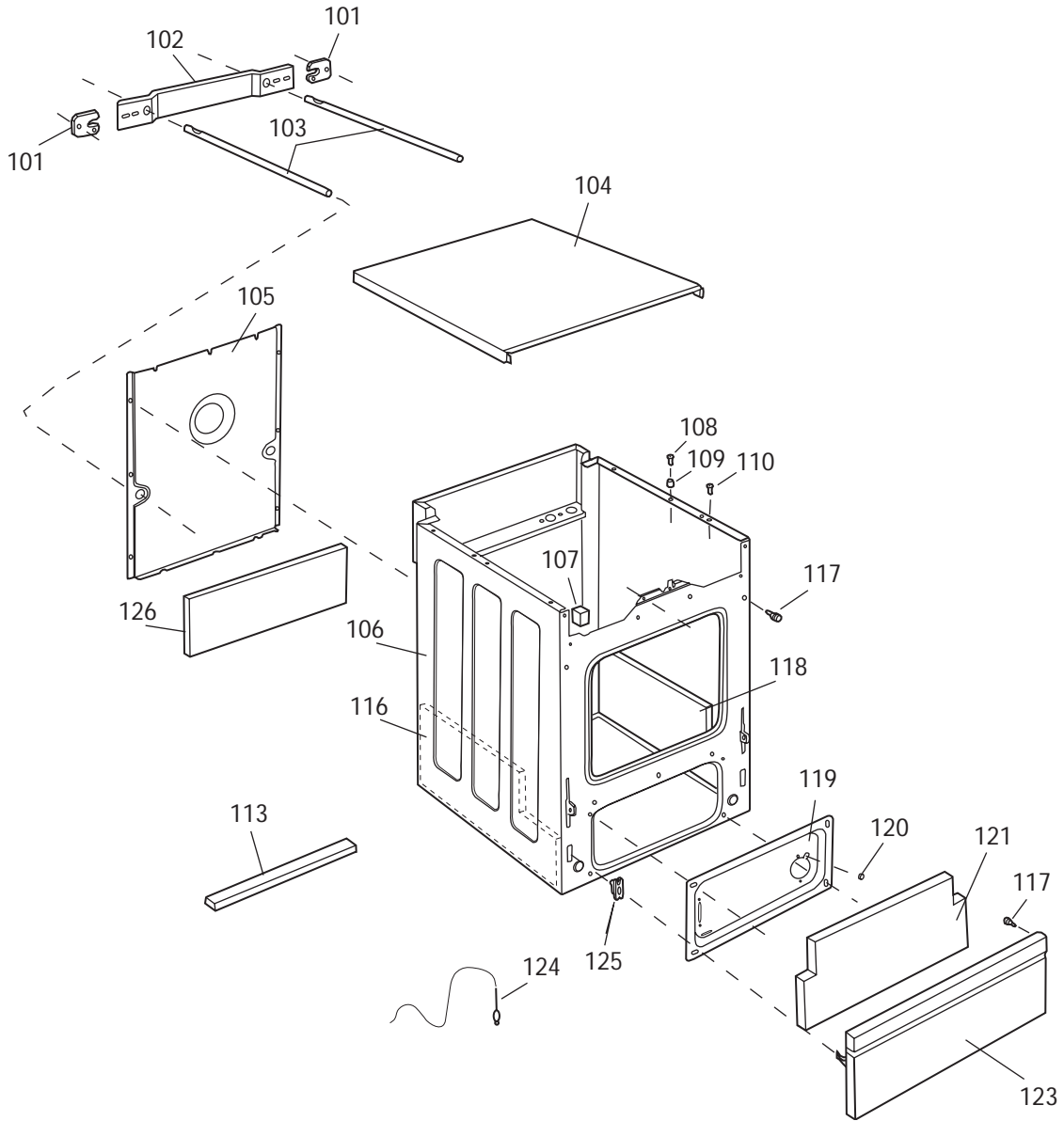

Cabinet & Related Parts

ASKO, 12505 US - white (WM100A)

Pos	Spare part No.	Description	Qty	Comment
101	8008209	Washer Shipping Security WM	2 Pc's	
101-a	8902023	Screw Plastic 25 Torx	2 Pc's	
102	8007873	No Longer available	1 Pc's	
103	8007643	No Longer Available	2 Pc's	
104	8057034-0	Top Washer 03/05	1 Pc's	
104-a	8900369	Screw T25	3 Pc's	
104-b	8901415	LOCK WASHER AZ 5.3 GALV	3 Pc's	
105	8052516	Rear Panel Washer	1 Pc's	
105-a	8900328	Screw	9 Pc's	
105-b	8901415	LOCK WASHER AZ 5.3 GALV	2 Pc's	
106	8056990-0	NOT AVAILABLE	1 Pc's	
107	8052555	Buffer	1 Pc's	
108	8901619	Pop Rivet - Det Comp	3 Pc's	
109	8059485	Securing Pin	4 Pc's	
110	8901620	POP-RIVET AL/ST 4X14Pop Rivet	1 Pc's	
113	8056469	No Longer Available	1 Pc's	
117	7382154	Rubber Buffer WM 03/05	2 Pc's	
119	8060964	Service Cover	1 Pc's	
119-a	8902362	Screw 20 Torx Self Tapping	4 Pc's	
119-b	8901413	Lock Washer laundry tops	2 Pc's	
119-c	8060929	Grommet	1 Pc's	
123	8008092-0	Lower Cover 03 W/D04/05 Wsh	1 Pc's	
124	8056889	Ring - Emergency Open	1 Pc's	
124-a	8900453	Screw - Opening	1 Pc's	
125	8007658	Holder-Lower Cover 03/05 TD/WM	2 Pc's	

Datum
2003-05-02
Date

YTTERLUCKA

OUTERDOOR AND RELATED PARTS

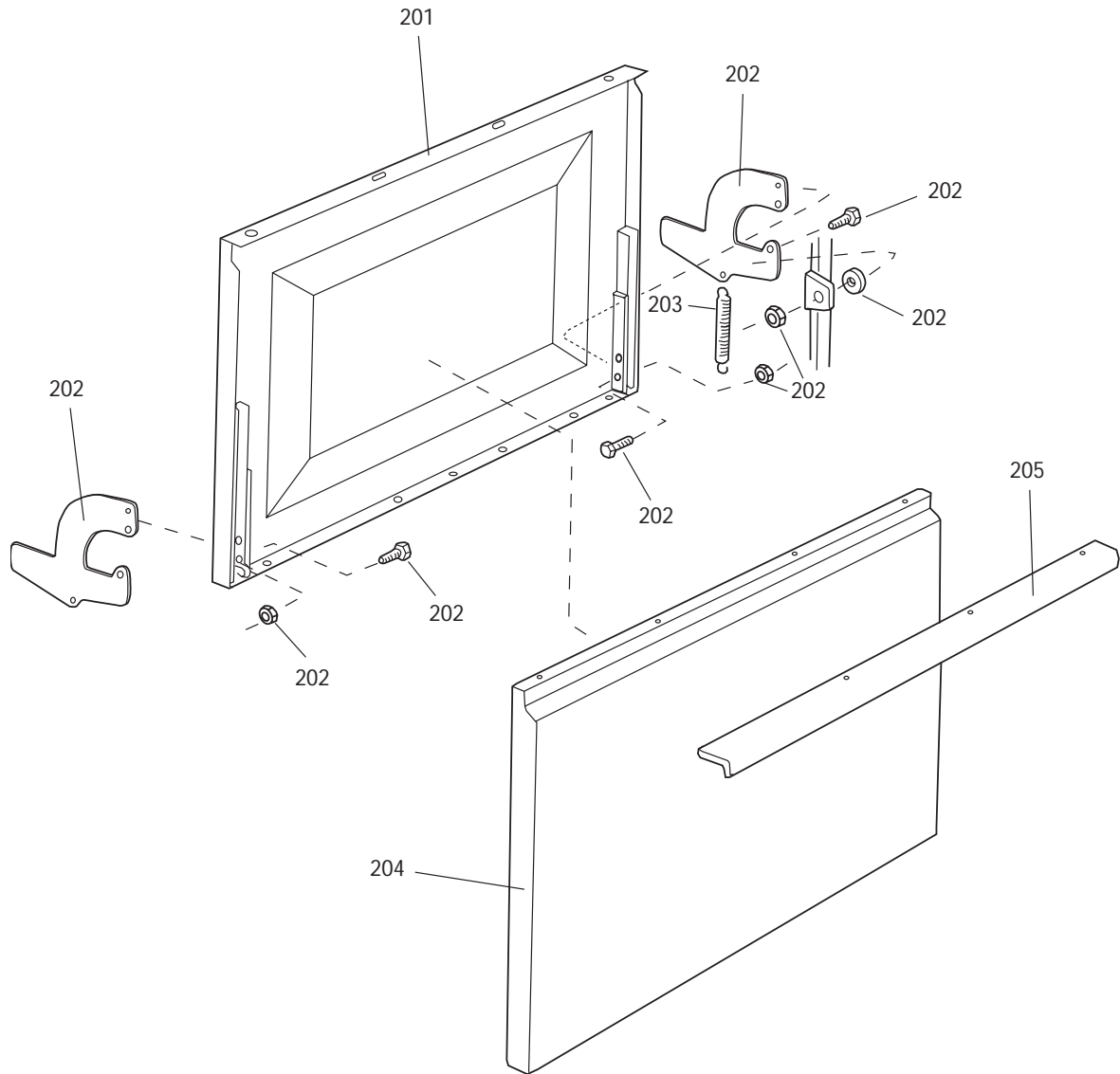

Door & Related Parts

ASKO, 12505 US - white (WM100A)

Pos	Spare part No.	Description	Qty	Comment
201	8055996-0	Inner Door White	1 Pc's	
202	33958694	Hinge - Washer	2 Pc's	
202-a	7382628	Nylon Washer	2 Pc's	
202-b	8901002	Screw	4 Pc's	
202-c	8901004	Screw	2 Pc's	
202-d	8901154	NUT M6 BH8 GALV	4 Pc's	
202-e	8901192	Locking Nut WM 03/05	2 Pc's	
203	8054952	Door Spring	1 Pc's	
204	8007750-0	Outer door White	1 Pc's	
204-a	8900346	Screw	4 Pc's	
205	8056420-0	Door Handle - Washer 04	1 Pc's	
205-a	8900395	Screw	4 Pc's	

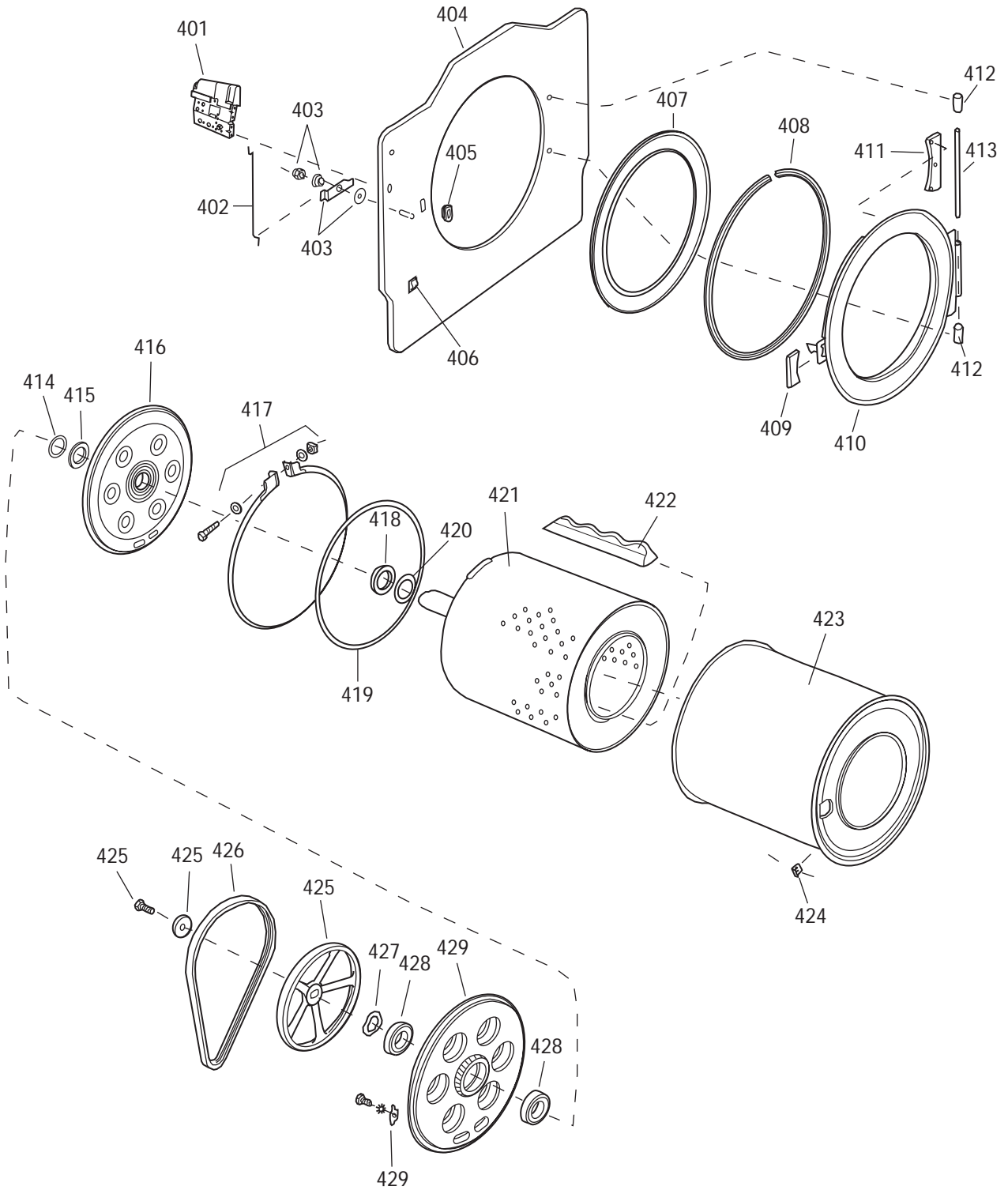

Cylinder & Container

ASKO, 12505 US - white (WM100A)

Pos	Spare part No.	Description	Qty	Comment
401	8055473	Door Switch - DW 05/06	1 Pc's	
401	8057594	LOCK COMPL. FRONTWASHER	1 Pc's	
401-a	8902362	Screw 20 Torx Self Tapping	4 Pc's	
402	8007879	Pull Rod	1 Pc's	
403	8055209	Lock Release	1 Pc's	
403-a	33202756	Bushing Door Lock 03/05	1 Pc's	
403-b	33256918	Spacer - Door Lock	1 Pc's	
403-c	8901192	Locking Nut WM 03/05	1 Pc's	
404	8008149-0	Cover Plate White	1 Pc's	
404-a	33525519	WASHER 5.3X13X1.0 FZB	2 Pc's	
404-b	8900950	SCREW M6S 8.8 M5X8 S-LOCK	2 Pc's	
405	33302953-0	Bushing Door Catch WM 03/04/05	1 Pc's	
406	8002498	Cable Bracket	1 Pc's	
407	8056351	NLA - Door Seal Washer 02/05	1 Pc's	
408	33303048	LockRing Door Seal WM 03/04/05	1 Pc's	
409	8059690-0	Cover door latch 05 Laundry	1 Pc's	
410	8801106-0	Glass Door Comp. WM03/04/05	Pc's	
410	8801106-0	Glass Door Comp. WM03/04/05	Pc's	
411	8062994	Hinge Glass Door 03/05 WM	1 Pc's	
411-a	33451808	Screw	3 Pc's	
412	8801177	Hinge Bushing Serv. Kit	1 Pc's	
413	8050583	Door Hinge Shaft WM 03/04	1 Pc's	
414	8056324	O-Ring 10504	1 Pc's	
415	8056323	Throw Ring WM90 A 100A 120A	1 Pc's	
416	8058380	Rear Part Cont.	1 Pc's	
417	8801105	Svc. Kit WM 200	1 Pc's	
418	8056309	VRing WM80A/90/90A/100A/140A	1 Pc's	
419	8062049	Seal Rear Washer Pane WM	1 Pc's	
421	8056316	Cylinda Out 10504	1 Pc's	
422	8053858	Drum Paddle WM 04/05	3 Pc's	
422-a	8902090	Screw	3 Pc's	
423	8056934	Container	1 Pc's	
424	8055677	Holder - Cover Plate	4 Pc's	
424-a	8901002	Screw	4 Pc's	
424-b	8901430	Spring Washer	4 Pc's	
425	8056376	Pulley for Drum WM	1 Pc's	
425-a	8057209	Washer Level Leg DW	1 Pc's	
425-b	8901052	Screw	1 Pc's	
426	8052054	Belt Antistatic WM200 A	1 Pc's	
427	8056810	Wave Washer - WM	1 Pc's	
428	8056314	Bearing Comp. WM Rear Panel	2 Pc's	
429	8056311	Rear Wall - 10504	1 Pc's	
429-a	33700183	Terminal	1 Pc's	
429-b	8901097	Screw Terminal	1 Pc's	
429-c	8901413	Lock Washer laundry tops	1 Pc's	

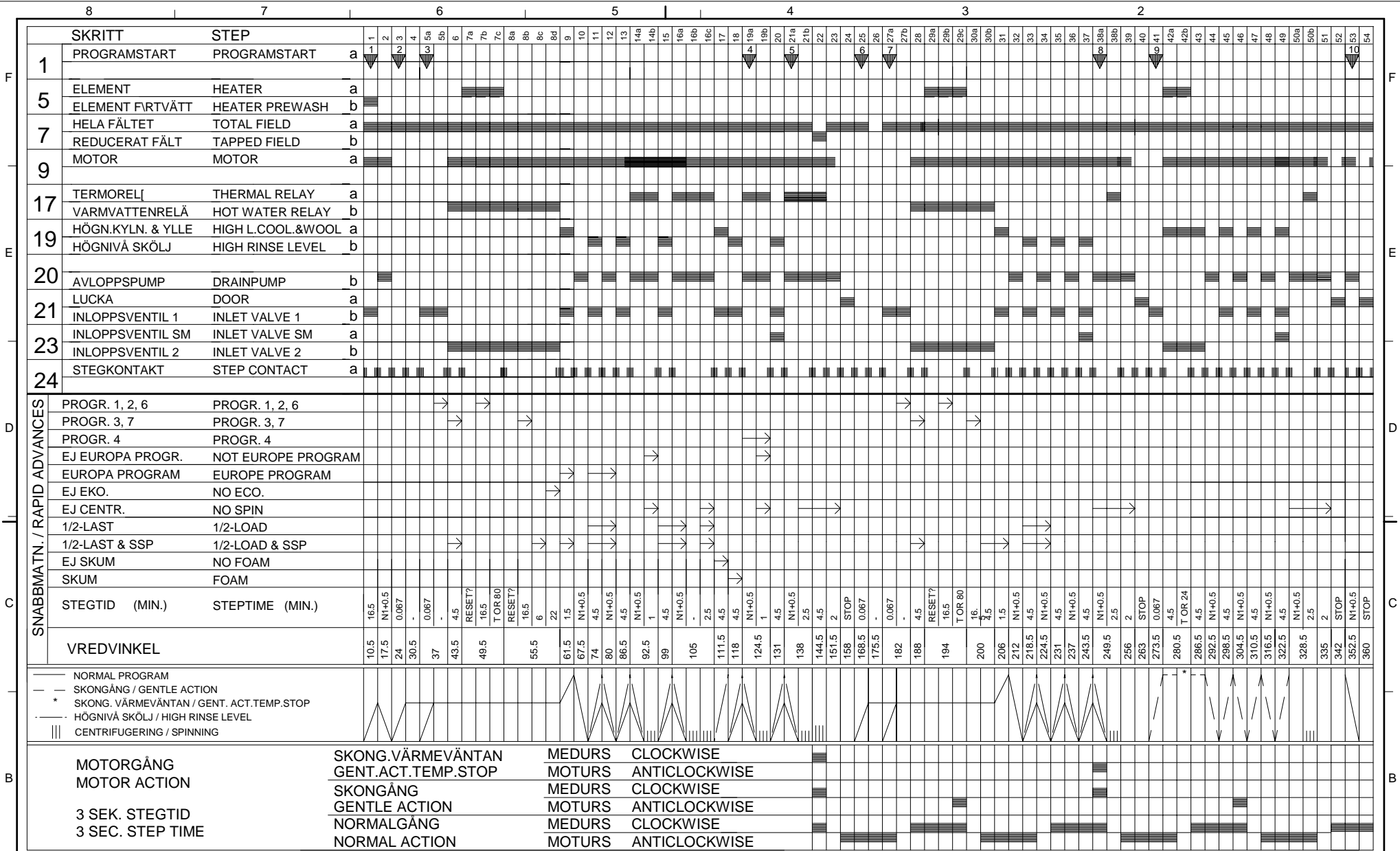

N1+0.5 : UTPUMPNING TILL NORMALNIVÅ ÅTERGÅNGSNIVÅ+YTTERLIGARE 30 SEK. DOCK TOTALT MAX 2 MINUTER
DRAINAGE TO RETURN LEVEL OF NORMAL LEVEL+FURTHER 30 SEC. TOTALY MAX 2 MINUTES.

T OR 80 RESP. T OR 24 : TID FÖR UPPVÄRMNING TILL VALD TEMPERATUR, DOCK MAX 80 RESP. 24 MIN.
TIME FOR UPHEATING TO SELECTED TEMPERATURE. HOWEVER MAX 80 RESP. 24 MIN

Article No	Name of item	Qty	Material,dimensions,type,etc.
Scale:	Gen.tolerance:	Description(English) TIMER DIAGRAM WM100	
Designed by MATS LJLJA	Drawn by CAD	Description(own language) TIMER DIAGRAM WM100	
Drawing checked by	Iss by Dep	Year	Week
	US	93	41
8058118			Rev Ind 00
			Replace Replaced by

Rev ind	Revision	Appd	Year	Week
---------	----------	------	------	------

KOMPLETTSCHEMA Nr.: 80 606 89

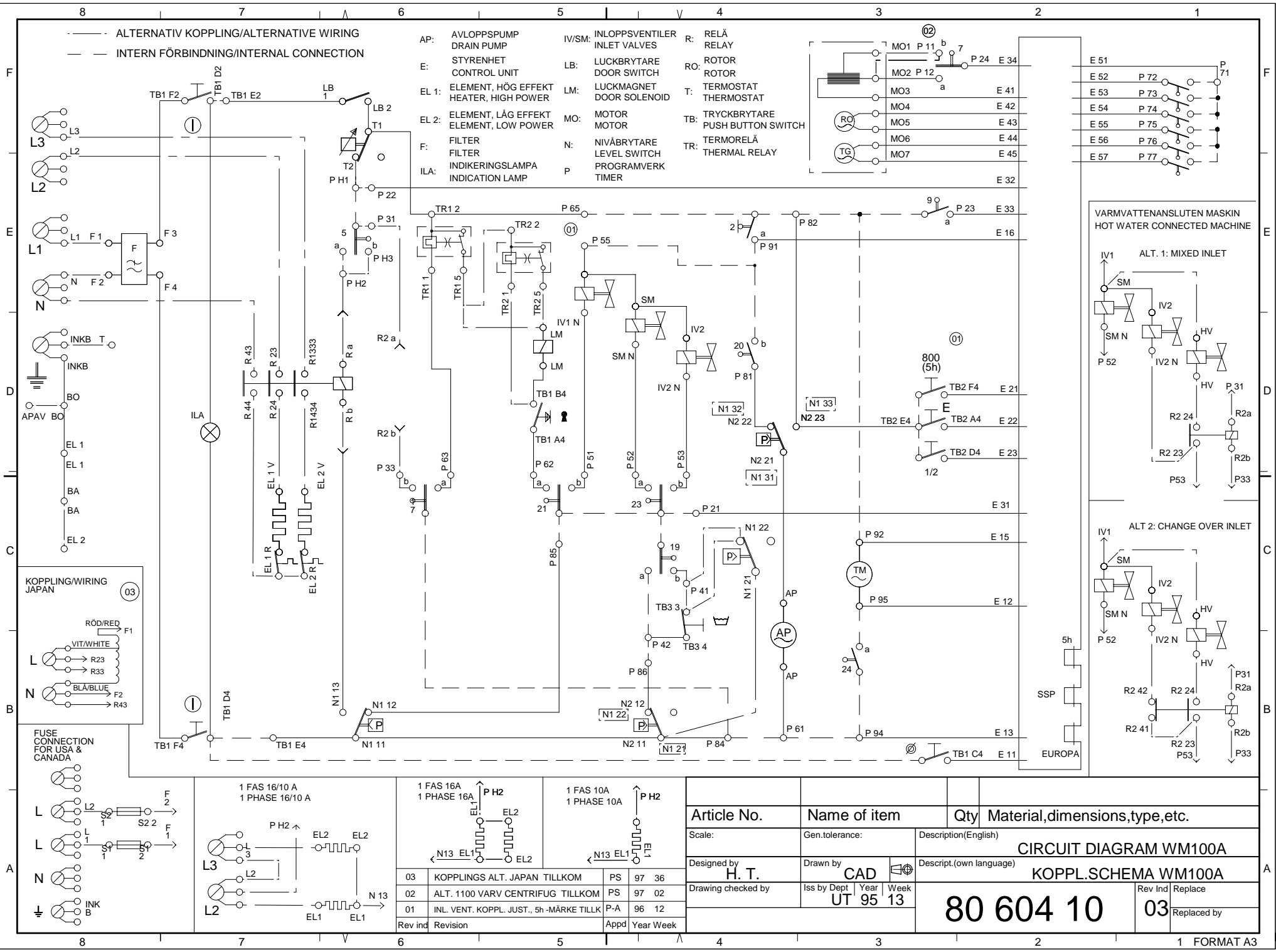

Article No.	Name of item	Qty	Material, dimensions, type, etc.
Scale: Gen. tolerance: Description(English)			
CIRCUIT DIAGRAM WM100A			
Description(own language)			
KOPPL.SCHEMA WM100A			
Designed by	Drawn by	Rev Ind Replace	
H. T.	CAD	03	03
Drawing checked by	Iss by Dept. Year Week	Replaced by	
	UT 95 13	80 604 10	

Rev ind	Revision	Appd	Year	Week
03	KOPPLINGS ALT. JAPAN TILLKOM	PS	97	36
02	ALT. 1100 VARV CENTRIFUG TILLKOM	PS	97	02
01	INL. VENT. KOPPL. JUST., 5h-MÄRKE TILLK	P-A	96	12

